



















ENGINE

BASE VEHICLE	CHARACTERISTICS	ENGINE	SEATS AUTHORISED FOR ROAD USE WITHOUT MOTORBIKE CARRIER	VEHICULE BODYCOACH WEIGHT IN RUNNING ORDER (+/- 5%)	MAX TECHNICALLY PERMISSIBLE LADEN MASS
	OVERCAB FLASH 03	2.2 L 115 HP	6	2844	3500
	OVERCAB FLASH 11	2.4 L 140 HP	5	3079 / 3246	3500 / 3850
	LOW PROFILE FLASH 04	2.2 L 115 HP	4	2764	3500
	LOW PROFILE FLASH 22	2.2 L 115 HP	4/5	2928 / 2942	3500
	LOW PROFILE FLASH 14	2.2 L 115 HP	4	2805	3500
	LOW PROFILE FLASH 28	2.2 L 115 HP	4	2998	3500
	LOW PROFILE FLASH S2	2.3 L 35M 130 HP	4	2830	3500
	LOW PROFILE FLASH 06	2.3 L 35 L 130 HP / 3 L 35 L 157 HP / 2.3 L 40H 130 HP / 3 L 40H 157 HP /	4	3008 / 3068 / 3048 / 3108	3500 / 3500 / 4000 / 4000
	LOW PROFILE FLASH 26	2.3 L 35 L 130 HP / 3 L 35 L 157 HP / 2.3 L 40H 130 HP / 3 L 40H 157 HP /	4	3126 / 3156 / 3166 / 3226	3500 / 3500 / 4000 / 4000
	LOW PROFILE FLASH 26	2.3 L 35 L 130 HP / 3 L 35 L 157 HP / 2.3 L 40H 130 HP / 3 L 40H 157 HP /	5	3079 / 3079 / 3179 / 3239	3500 / 3500 / 4000 / 4000
	LOW PROFILE WELCOME 64	2.3 L 35 L 130 HP / 3 L 35 L 157 HP / 2.3 L 40H 130 HP / 3 L 40H 157 HP /	4	2992 / 3052 / 3032 / 3092	3500 / 3500 / 4000 / 4000
	LOW PROFILE WELCOME 88	2.3 L 35 L 130 HP / 3 L 35 L 157 HP / 2.3 L 40H 130 HP / 3 L 40H 157 HP /	4	3102 / 3092 / 3142 / 3202	3500 / 3500 / 4000 / 4000
	LOW PROFILE WELCOME 78	2.3 L 35 L 130 HP / 3 L 35 L 157 HP / 2.3 L 40H 130 HP / 3 L 40H 157 HP /	4	3159 / 3149 / 3199 / 3259	3500 / 3500 / 4000 / 4000
	LOW PROFILE WELCOME 78EB	2.3 L 35 L 130 HP / 3 L 35 L 157 HP / 2.3 L 40H 130 HP / 3 L 40H 157 HP /	4	3159 / 3149 / 3224 / 3284	3500 / 3500 / 4000 / 4000
	LOW PROFILE WELCOME 98	2.3 L 35 L 130 HP / 3 L 35 L 157 HP / 2.3 L 40H 130 HP / 3 L 40H 157 HP /	4	3160 / 3150 / 3200 / 3260	3500 / 3500 / 4000 / 4000
	LOW PROFILE SWEET MINI	2.3 L 35 L 130 HP / 3 L 35 L 157 HP / 2.3 L 40H 130 HP / 3 L 40H 157 HP /	4	2894 / 2954 / 2934 / 2994	3500 / 3500 / 4000 / 4000
	LOW PROFILE SWEET MAXI	2.3 L 35 L 130 HP / 3 L 35 L 157 HP / 2.3 L 40H 130 HP / 3 L 40H 157 HP /	4	3021 / 3081 / 3061 / 3121	3500 / 3500 / 4000 / 4000
	LOW PROFILE SWEET GA	2.3 L 35 L 130 HP / 3 L 35 L 157 HP / 2.3 L 40H 130 HP / 3 L 40H 157 HP /	4	3154 / 3154 / 3234 / 3294	3500 / 3500 / 4000 / 40

Weight empty in running order: the weight empty in running order includes the weight of the driver (75 Kg) and 100 % of the water, 90 % fuel and 100 % gas tanks. Tolerance +/- 5%. The indicated weights empty in running order only take account of series equipment (+/-5%). The manufacturer reserves the right to alter this equipment list at any time.

- Accessories fitted as an option are not included when determining the weight empty. Their weight should therefore be deducted from the available payload.
- You may be able to find certain heavy accessories like large blinds or generators in the marketplace. The weight of these accessories should be deducted from the payload and could possibly lead to a reduction in the actual passenger numbers. It is therefore important not to exceed the maximum loads on axles and the technically acceptable loaded weight when the vehicle is fully loaded.
- Some models photographed in this catalogue may be shown with equipment supplied as an option. The characteristics of photographed models may vary from one country to the next. Despite the care taken in producing this catalogue, this cannot be viewed as a contractual document. CHAUSSON reserves the right to modify its models without prior notice. CHAUSSON cannot be held liable for any modifications made by its suppliers nor typographical errors when printing these documents. It is forbidden to reproduce, even partially, text or document. Do not litter the public highway.
- Your retailer is at your disposal to advise you and provide you with any additional information.

NB: All the technical characteristics for Chausson valid at the time of printing (August 2011) are provided for information only. They may be subject to modifications, often as a result of technical improvements. The certificate of approval (issued by the vehicles inspection authorities) meets legal requirements, in particular with respect to weights and dimensions.



BP 109 - 07302 TOURNON CEDEX - Tél. (33) 04 75 07 55 00 - Fax (33) 04 75 07 55 58
Internet : www.chausson.tm.fr - E. mail : contact@chausson.tm.fr

GOOD IDEAS - UK - RCS B 408 502 508 PARIS

TECHNICAL CHARACTERISTICS 2011



Flash OVERCABS 03 - 11 ————— Page 2 / 11

Flash LOW PROFILES MODELS S2 - 04 - 06 - 14 - 22 - 26 - 28 ————— Page 2 / 11

Welcome LOW PROFILES MODELS 64 - 78 - 78 EB - 88 - 98 ————— Page 4 / 11

Suite LOW PROFILES MODELS Mini - Maxi - Garage ————— Page 4 / 11



Flash

OVERCABS

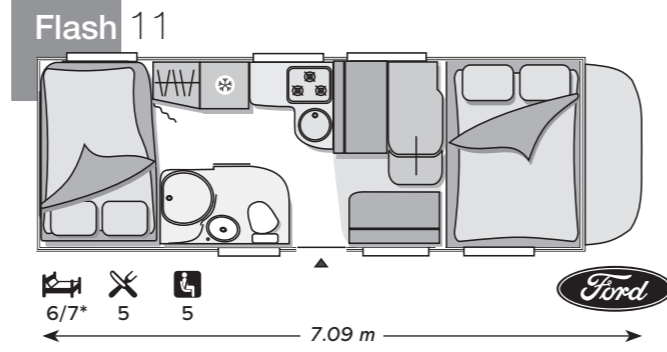
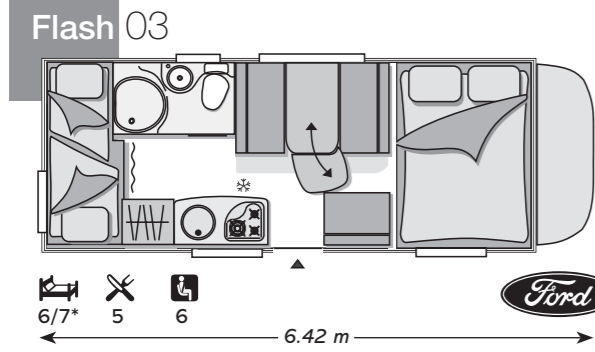

LOW PROFILES MODELS

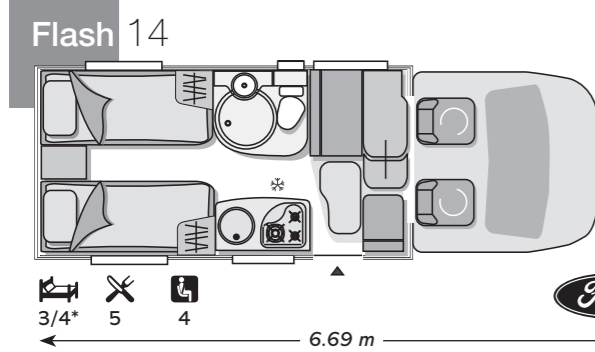
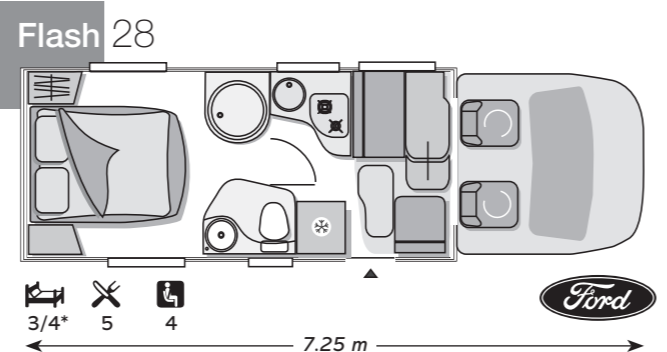
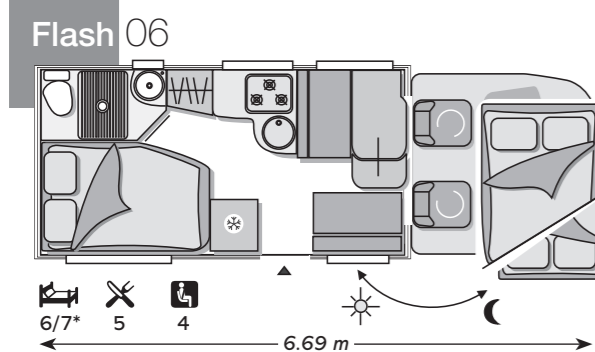
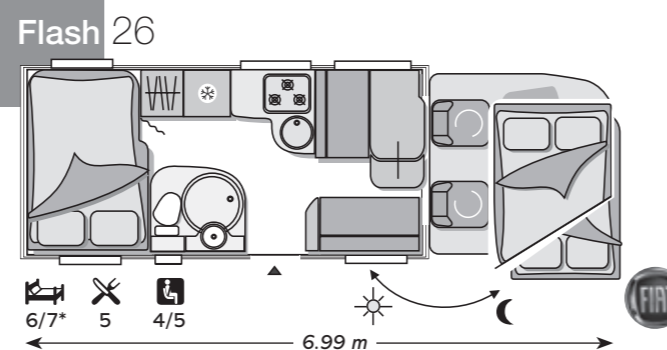
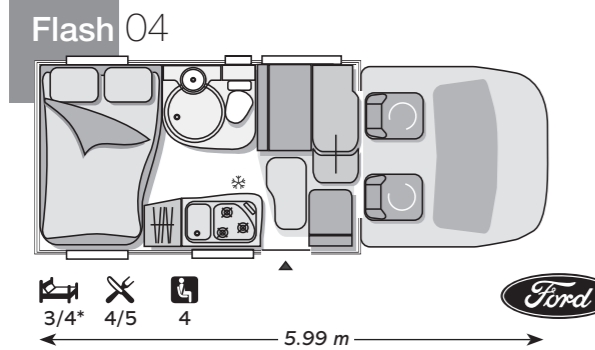
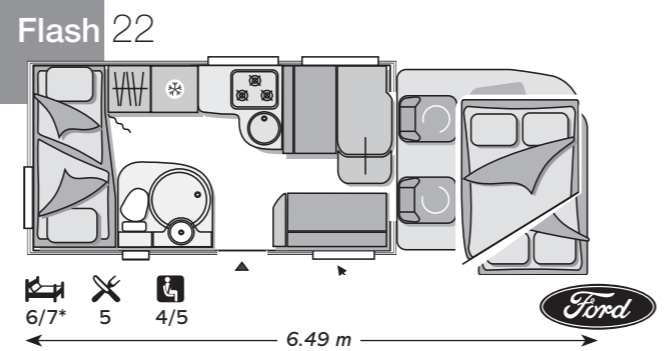
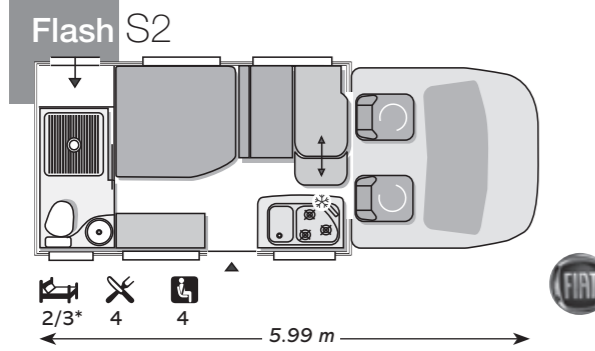

CHARACTERISTICS	BASE VEHICLE								
	OVERCABS		LOW PROFILES MODELS						
	FLASH 03	FLASH 11	FLASH S2	FLASH 04	FLASH 06	FLASH 14	FLASH 22	FLASH 26	FLASH 28
BASE VEHICLE	FORD TRANSIT 350 L 3750	FORD TRANSIT 350 L REAR TWIN WHEELS	FIAT DUCATO 35 M 3450	FORD TRANSIT 350 M 3300	FIAT DUCATO 35 L 3800	FORD TRANSIT 350 L 3750	FORD TRANSIT 350 L 3950	FIAT DUCATO 35 L 4035	FORD TRANSIT 350 L 3950
Engine	2.2 L	2.4 L	2.3 L	2.2 L	2.3 L	2.2 L	2.2 L	2.3 L	2.2 L
Engine power	140 HP	140 HP	130 HP	140 HP	130 HP	140 HP	140 HP	130 HP	140 HP
Manual gear box 6 position	S	S	S	S	S	S	S	S	S
Wide track rear axle	S	■	S	S	S	S	S	S	S
ABS	S	S	S	S	S	S	S	S	S
Power steering	S	S	S	S	S	S	S	S	S
Electric, de-icing rearview mirrors	S	S	S	S	S	S	S	S	S
Electric windows	S	S	S	S	S	S	S	S	S
Cab doors central locking	S	S	S	S	S	S	S	S	S
Ignition interlock system	S	S	S	S	S	S	S	S	S
Driver seat adjustable for height	S	S	S	S	S	S	S	S	S
Passenger seat adjustable for height	S	S	S	S	S	S	S	S	S
Cab seats with double armrest	S	S	S	S	S	S	S	S	S
Cab seat covers with matching cushions (1 Kg)	S	S	S	S	S	S	S	S	S
Driver air bag	S	S	S	S	S	S	S	S	S
Passenger air bag	S	S	S	S	S	S	S	S	S
Pre-wired radio (cabin)	S	S	S + LS	S	S + LS	S	S	S + LS	S
Cab shaded by insulating curtains	O	O	O	O	S	O	S	S	O
Cab carpet (2 Kg)	S	S	S	S	S	S	S	S	S
Cab air conditioning (25 Kg)	O	O	O	O	O	O	O	O	O
Reverse sensor with audible cab beeper	O	O	O	O	O	O	O	O	O
Silver Pack + Cab air conditioning (20 Kg)	O	O	O	O	O	O	O	O	O
Cruise control	S	S	S	S	S	S	S	S	S
WEIGHT									
Vehicle bodycoach weight in running order (+/- 5%)	2844	3079	2830	2764	3008	2805	2928 / 2942	3126 / 3079	2998
Max technically permissible laden mass	3500	3500	3500	3500	3500	3500	3500	3500	3500
DIMENSIONS									
Overall length (excl. ladder)	6.42	7.09	5.99	5.99	6.69	6.69	6.49	6.99	7.25
Overall width	2.30	2.30	2.30	2.30	2.30	2.30	2.30	2.30	2.30
Overall height (excl. roof rack)	2.93	3.08	2.76	2.76	2.89	2.76	2.89	2.89	2.76
Interior height	2.04 / 2.12	2.04 / 2.12	1.98	1.98	2.11	1.98	2.11	2.11	1.98
Wheelbase	3.75	3.95	3.45	3.30	3.80	3.75	3.95	4.03	3.95
CAPACITY									
Seats authorised for road use without motorbike carrier (1)	6	5	4	4	4	4	4 / 5	4 / 5	4
Dining seats	5	5	4	4 / 5	5	5	5	5	5
Sleeping berths	6 / 7*	6 / 7*	2 / 3*	3 / 4*	6 / 7*	3 / 4*	6 / 7*	6 / 7*	3 / 4*

■ : Can't be fitted on S : Standard equipment O : Option *Extra bed possible with optional accessory (1) According homologation

Welcome



LOW PROFILES MODELS

Welcome 64

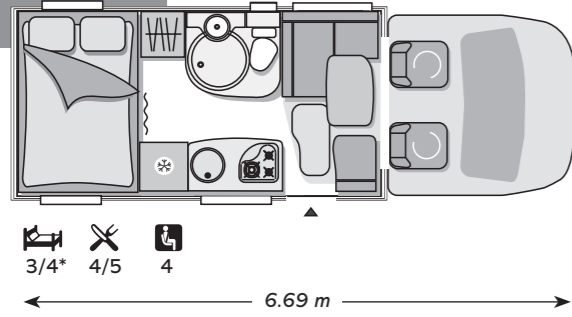

Welcome 78

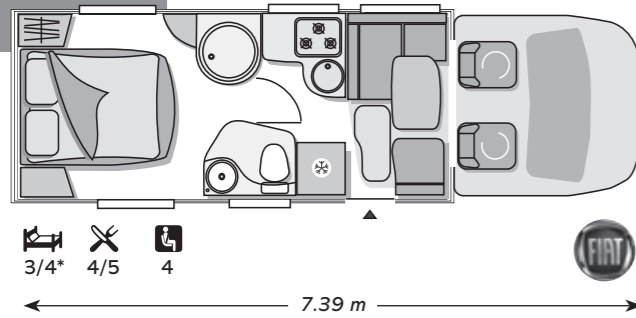

Welcome 78 EB

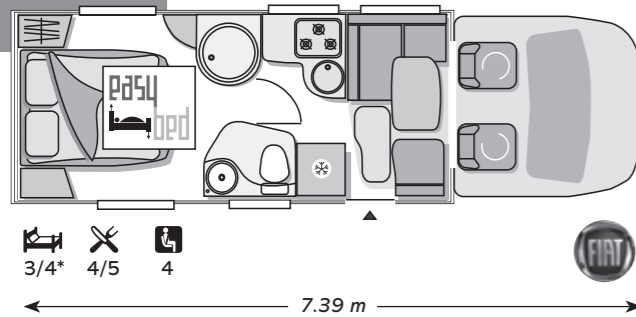

Welcome 88

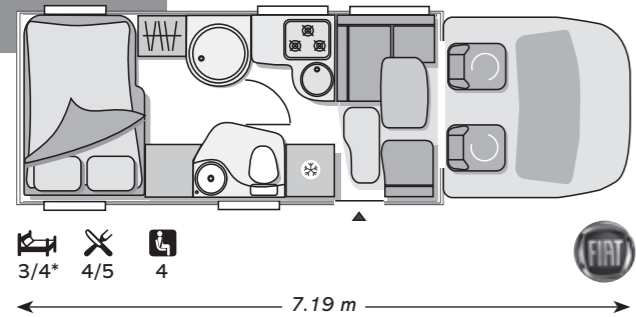

Welcome 98

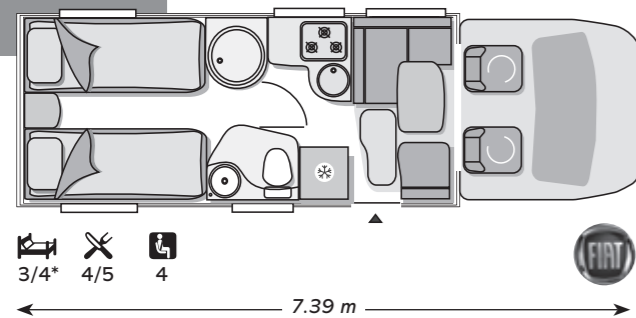

Suite



LOW PROFILES MODELS

Suite Mini

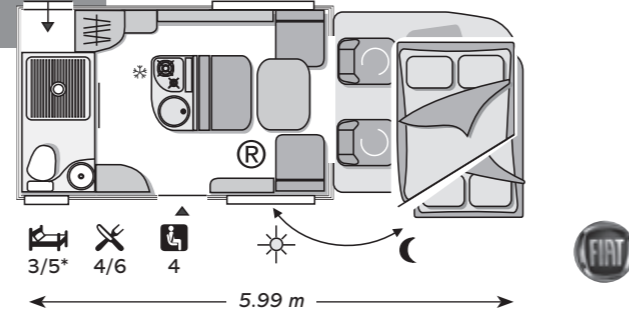

Suite Maxi

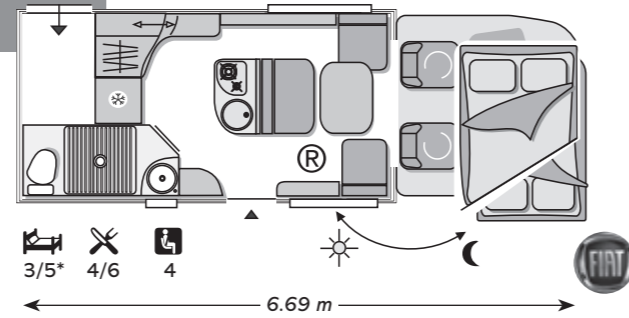

Suite Garage

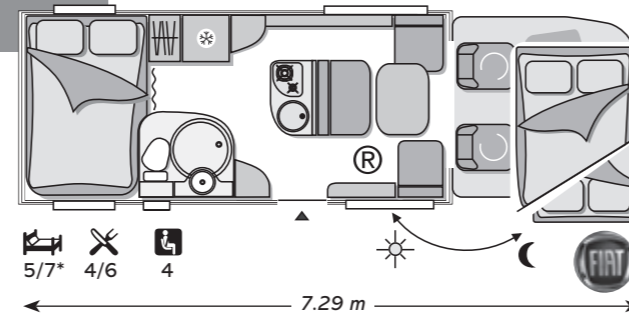

B A S E V E H I C L E

LOW PROFILES MODELS WELCOME

LOW PROFILES MODELS SUITE

CHARACTERISTICS	WELCOME					SUITE		
	WELCOME 64	WELCOME 78	WELCOME 78EB	WELCOME 88	WELCOME 98	SUITE MINI	SUITE MAXI	SUITE GARAGE
BASE VEHICLE	FIAT DUCATO 35 L 3800	FIAT DUCATO 35 L 4035	FIAT DUCATO 35 L 4035	FIAT DUCATO 35 L 4035	FIAT DUCATO 35 L 4035	FIAT DUCATO 35 L 3800	FIAT DUCATO 35 L 3800	FIAT DUCATO 35 L 4035
Engine	2.3 L	2.3 L	2.3 L	2.3 L	2.3 L	2.3 L	2.3 L	2.3 L
Engine power	130 HP	130 HP	130 HP	130 HP	130 HP	130 HP	130 HP	130 HP
Manual gear box 6 position	S	S	S	S	S	S	S	S
Wide track rear axle	S	S	S	S	S	S	S	S
GRP	S	S	S	S	S	S	S	S
Power steering	S	S	S	S	S	S	S	S
Electric, de-icing rearview mirrors	S	S	S	S	S	S	S	S
Electric windows	S	S	S	S	S	S	S	S
Cab doors central locking	S	S	S	S	S	S	S	S
Ignition interlock system	S	S	S	S	S	S	S	S
Driver seat adjustable for height	S	S	S	S	S	S	S	S
Passenger seat adjustable for height	S	S	S	S	S	S	S	S
Cab seats with double armrest	S	S	S	S	S	S	S	S
Cab seat covers with matching cushions (1 Kg)	S	S	S	S	S	S	S	S
Driver air bag	S	S	S	S	S	S	S	S
Passenger air bag	S	S	S	S	S	S	S	S
Pre-wired radio (cabin)	S + LS	S + LS	S + LS	S + LS	S + LS	S + LS	S + LS	S + LS
Cab shaded by insulating curtains	S	S	S	S	S	S	S	S
Cab carpet (2 Kg)	S	S	S	S	S	S	S	S
Cab air conditioning (25 Kg)	O	O	O	O	O	O	O	O
Reverse sensor with audible cab beeper	S	S	S	S	S	S	S	S
Silver Pack + Cab air conditioning (20 Kg)	O	O	O	O	O	O	O	O
Cruise control	S	S	S	S	S	S	S	S
WEIGHT								
Vehicle bodycoach weight in running order (+/- 5%)	2992	3159	3159	3102	3160	2894	3021	3154
Max technically permissible laden mass	3500	3500	3500	3500	3500	3500	3500	3500
DIMENSIONS								
Overall length (excl. ladder)	6.69	7.39	7.39	7.19	7.39	5.99	6.69	7.29
Overall width	2.30	2.30	2.30	2.30	2.30	2.30	2.30	2.30
Overall height (excl. roof rack)	2.76	2.76	2.76	2.76	2.76	2.89	2.89	2.89
Interior height	1.98	1.98	1.98	1.98	1.98	2.11	2.11	2.11
Wheelbase	3.80	4.03	4.03	4.03	4.03	3.80	3.80	4.03
CAPACITY								
Seats authorised for road use without motorbike carrier (1)	4	4	4	4	4	4	4	4
Dining seats	4 / 5	4 / 5	4 / 5	4 / 5	4 / 5	4 / 6	4 / 6	4 / 6
Sleeping berths	3 / 4*	3 / 4*	3 / 4*	3 / 4*	3 / 4*	3 / 5*	3 / 5*	5 / 7*

■ : Can't be fitted on S : Standard equipment O : Option *Extra bed possible with optional accessory (1) According homologation

LIVING UNIT	FLASH									WELCOME					SUITE		
	OVERCABS		LOW PROFILES MODELS							LOW PROFILES MODELS					LOW PROFILES MODELS		
CHARACTERISTICS	FLASH 03	FLASH 11	FLASH S2	FLASH O4	FLASH O6	FLASH 14	FLASH 22	FLASH 26	FLASH 28	WELCOME 64	WELCOME 78	WELCOME 78 EB	WELCOME 88	WELCOME 98	SUITE MINI	SUITE MAXI	SUITE GARAGE
EXTERIOR																	
Polyester coachwork + anti-hail roof	S	S	S	S	S	S	S	S	S	S	S	S	S	S	S	S	S
Floor, 62 mm thick	S	S	S	S	S	S	S	S	S	S	S	S	S	S	S	S	S
Rear corner steadies (18 Kg)	O	O	■	O	O	O	O	O	O	O	O	O	O	O	■	O	O
Electric step (2 Kg)	■	O	■	■	■	■	■	■	■	■	■	■	■	■	S	S	S
Storage locker with exterior access	S	Garage	S	Easy Bed	S	S	S	Easy Bed	S	Easy Bed	S	Easy Bed	Easy Bed	S	S	S	Easy Bed
1 x 13 Kg propane gas bottle locker	S	S	S	S	S	S	S	S	S	S	S	S	S	S	S	S	S
Factory fitted cross-bar for bike-rack	S	S	S	S	S	S	S	S	S	S	S	S	S	S	S	S	S
B.U.S (Bike up system)	■	■	■	■	■	■	■	■	■	■	■	■	■	■	■	O	■
INTERIOR																	
Dividing curtain cab / living unit	S	S	S	S	S	S	S	S	S	S	S	S	S	S	S	S	S
Entrance door with flyscreen (1 Kg)	S	S	S	S	S	S	S	S	S	S	S	S	S	S	S	S	S
Automatic entrance cell lights	■	■	■	■	■	■	■	■	■	S	S	S	S	S	S	S	S
Panoramic skylight 700 x 500	S	S	S	S	S	S	S	S	S	■	■	■	■	■	S	S	S
Panoramic skylight 900 x 600	■	■	■	■	■	■	■	■	■	S	S	S	S	S	■	■	■
Cab panoramic skylight	■	■	■	■	O	■	O	O	■	S	S	S	S	S	S	S	S
12 V fan skylight galley / living area	■	■	■	■	■	■	■	■	■	S	S	S	S	S	■	■	S
TV Sliding plate (4 Kg)	S	S	S	S	S	S	S	S	S	S	S	S	S	S	S	S	S
Electric telescopic table leg (T SYSTEM)	■	■	■	■	■	■	■	■	■	S	S	S	S	S	S	S	S
KITCHEN																	
Sink and 3 element inset hob	S	S	S	S	S	S	S	S	2 Hob	S	S	S	S	S	2 Hob	2 Hob	2 Hob
Gas refrigerator 12 V / 220 V	100 L	145 L	90 L	90 L	145 L	100 L	145 L	145 L	145 L	175 L	175 L	175 L	175 L	175 L	90 L	175 L	175 L
Cooker hood	■	■	■	■	■	■	■	■	■	■	■	■	■	■	O	O	O
Gas oven	■	■	■	■	■	■	■	■	■	■	S	S	S	S	■	S	S
Grill	S	S	S	S	S	S	S	S	S	S	■	■	■	■	■	■	■

■ : Can't be fitted on S : Standard equipment O : Option

LIVING UNIT	FLASH									WELCOME					SUITE		
	OVERCABS		LOW PROFILES MODELS							LOW PROFILES MODELS					LOW PROFILES MODELS		
CHARACTERISTICS	FLASH 03	FLASH 11	FLASH S2	FLASH O4	FLASH O6	FLASH 14	FLASH 22	FLASH 26	FLASH 28	WELCOME 64	WELCOME 78	WELCOME 78 EB	WELCOME 88	WELCOME 98	SUITE MINI	SUITE MAXI	SUITE GARAGE
BATHROOM																	
WC cassette removable from exterior	S	S	S	S	S	S	S	S	S	S	S	S	S	S	S	S	S
Separate shower	S	S	S	S	S	S	S	S	S	S	S	S	S	S	S	S	S
Double bond on shower stalls	■	■	S	S	■	S	S	S	S	S	S	S	S	S	S	S	S
Opaque window	S	S	S	S	S	S	S	S	S	S	S	S	S	S	S	S	S
Skylight with screen	■	■	S	S	S	S	S	S	S	S	S	S	S	S	S	S	S
WATER EQUIPMENT																	
Fresh water capacity	127 L	127 L	105 L	127 L	140 L	127 L	127 L	140 L / 70 L	127 L	140 L	140 L / 70 L	140 L / 70 L	140 L / 70 L	140 L / 70 L	105 L	105 L	105 L
Waste water capacity	106 L	102 L	105 L	106 L	105 L	106 L	106 L	105 L	106 L	105 L	105 L	105 L	105 L	105 L	105 L	105 L	105 L
Isolated waste water tank	■	■	■	■	■	■	■	■	■	O	O	O	O	O	O	O	O
HEATING																	
Combined heater / water heater with pulsed air using vehicle fuel 6000W	■	S	■	■	■	■	■	■	■	■	S	S	S	S	■	■	■
Boiler for the heating with pulsed air using vehicle fuel	S	■	S	S	S	S	S	S	S 5500W	S	■	■	■	■	S	S	S 5500W
On the road heating	S	S	S	S	S	S	S	S	S	S	S	S	S	S	S	S	S
Storage water heater with electronic ignition	S	■	S	S	S	S	S	S	S	S	■	■	■	■	S	S	S
ELECTRICAL EQUIPMENT																	
Halogen spotlights	S	S	S	S	S	S	S	S	S	S	S	S	S	S	S	S	S
Lighting in locker	S	S	■	S	■	■	S	S	S	S	S	S	S	S	S	S	S
Lighting in wardrobe	■	■	S	■	■	■	■	■	■	S	S	S	S	S	S	S	S
Exterior lighting	■	■	■	■	■	■	■	■	■	S	S	S	S	S	S	S	S
230 V / 12 V transformer with charger	S	S	S	S	S	S	S	S	S	S	S	S	S	S	S	S	S
Battery cell	S	S	S	S	S	S	S	S	S	S	S	S	S	S	S	S	S
Electronic control panel	S	S	S	S	S	S	S	S	S	S	S	S	S	S	S	S	S
Low battery voltage alarm living unit	S	S	S	S	S	S	S	S	S	S	S	S	S	S	S	S	S
230 V socket microwave location	■	■	■	■	■	■	■	■	■	■	■	■	■	■	■	■	■
220 V socket	3	3	2	2	2	2	2	2	3	3	3	3	3	3	2	2	3
12 V socket	3	3	2	2	2	2	2	2	3	3	3	3	3	3	2	2	3
TV preparation 12 V / 220 V	S (x1)	S (x1)	S (x1)	S (x1)	S (x1)	S (x1)	S (x1)	S (x1)	S (x2)	S (x2)	S (x2)	S (x2)	S (x2)	S (x2)	S (x1)	S (x1)	S (x2)
Radio preparation with 2 loudspeakers living units (1 Kg)	■	■	■	■	■	■	■	■	■	S	S	S	■	■	S	S	S

■ : Can't be fitted on S : Standard equipment O : Option

LIVING UNIT	FLASH									WELCOME					SUITE		
	OVERCABS		LOW PROFILES MODELS							LOW PROFILES MODELS					LOW PROFILES MODELS		
CHARACTERISTICS	FLASH 03	FLASH 11	FLASH S2	FLASH O4	FLASH O6	FLASH 14	FLASH 22	FLASH 26	FLASH 28	WELCOME 64	WELCOME 78	WELCOME 78 EB	WELCOME 88	WELCOME 98	SUITE MINI	SUITE MAXI	SUITE GARAGE
SLEEPING BERTH																	
Over-the-cab berth	155 x 217	155 x 203	■	■	■	■	■	■	■	■	■	■	■	■	■	■	■
Berth in central or forward dining area	130 x 176	120 / 100 x 215	■	50 / 90 x 215	120 x 215 / 140 x 191	50 / 90 x 215	120 x 215 / 140 x 191	120 x 215 / 140 x 191	57 / 90 x 215	110 / 50 x 215	110 / 55 x 215	110 / 55 x 215	110 / 55 x 215	110 / 55 x 215	100 x 184 / 140/129 x 193	100 x 184 / 140/129 x 193	100 x 184 / 140/129 x 193
Lower berth	82 / 66 x 215	■	■	■	■	■	215 x 95-81	■	■	■	■	■	■	■	■	■	■
Upper berth	82 / 66 x 215	■	■	■	■	■	215 x 95-81	■	■	■	■	■	■	■	■	■	■
Rear fixed bed	■	139 / 124 x 209	135 x 190	136 / 117 x 205	190 x 134-104	84 x 206 / 84 x 206	■	204 x 138-126	140 x 190	204 x 142	140 x 190	140 x 190	204 x 138 / 126	204 x 87 / 208 x 87	■	■	202 x 136 / 125
Over-the-cab height mattress / ceiling	■	de 102 à 80	■	de 70 à 105	■	■	■	de 86 à 119	■	De 72 à 107	■	De 77 à 112	De 73 à 108	■	■	■	De 121 à 86
Height mattress / ceiling	60 / 63	71 / 74	■	■	■	■	■	■	■	■	■	■	■	■	132 / 72	132 / 72	132 / 72
Rise and fall bed	■	S	■	Easybed	■	■	■	Easybed	■	Easy Bed	■	Easybed	Easy Bed	■	■	■	Easy Bed
Berth dining area accessory	■	■	■	O	■	O	■	■	O	O	O	O	O	O	O	O	O
Cab berth accessory	O	O	O	O	O	O	O	O	O	O	O	O	O	O	O	O	O
STORAGE DIMENSIONS : . Volumes and storage doors dimension . Locker capacities (dm³)																	
Side on right	1145 x 590	1295 x 1145	■	1145 x 845	445 x 1295	445 x 1295	1145 x 795	1145 x 845	895 x 590	1145 x 845	895 x 590	1145 x 695	1145 x 845	1045 x 845	■	■	1145 x 845
Side on left	795 x 385	1295 x 845	1045 x 590	795 x 385	■	385 x 795	795 x 385	795 x 385	795 x 385	895 x 590	795 x 385	795 x 385	895 x 590	1045 x 845	1045 x 590	1845 x 695	895 x 590
Facing rear	■	■	■	■	■	■	■	■	■	■	■	■	■	■	■	■	■
Gross capacity main locker dm ³	600	3280 à 3930	764	2900 / 1950	1160	1350	750	1950 à 2650	1460	2460	1550	De 2250 à 2940	De 2450 à 3430	2640	630	2370	De 2540 à 3590
ANOTHERS OPTIONS																	
Tow Hitch (24 Kg)	O	O	O	O	O	O	O	O	O	O	O	O	O	O	O	O	O
Motorbike carrier* (64 Kg)	O	O	■	■	O	O	O	O	■	O	■	■	O	■	O	O	■

*The "motorbike carrier" optional equipment can in some cases modify the number of seats authorised for road use. Consult your dealer for further information
 (1) Certain heavy accessories, such as large blinds or electric generators may be on offer to you on the market. The weight of these accessories will be deducted from the payload and may require a reduction in the actual number of passengers. Thus, the maximum permitted loads on the axes and the PTAC (maximum permitted weight) must be adhered to during full loading of the vehicle.

■ : Can't be fitted on S : Standard equipment O : Option